

SOURCE OF LIGHT

(THEORY OF EVERYTHING)

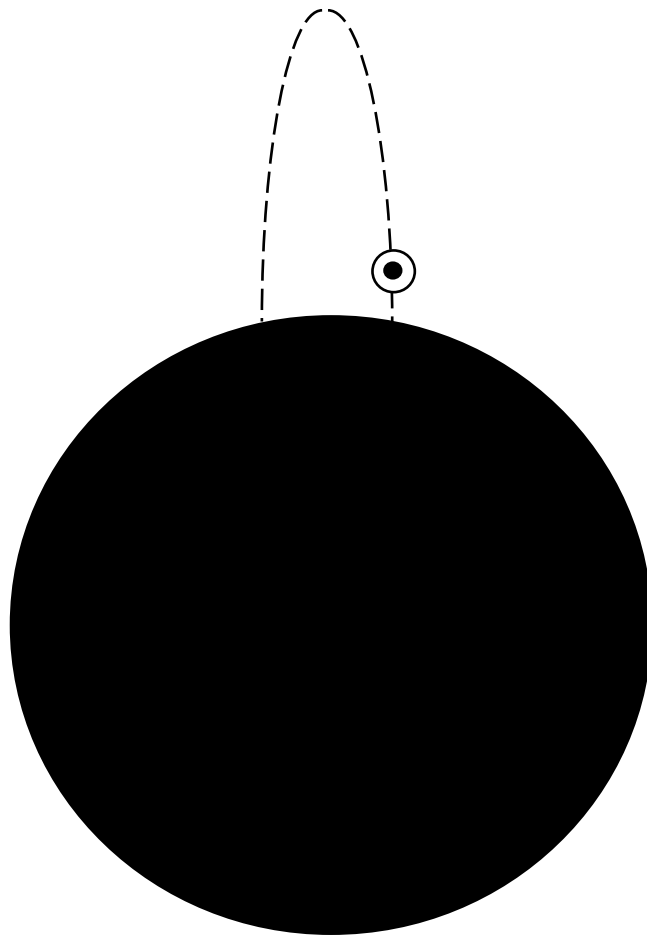

DRITAN ALPHA

“Reality is merely an illusion, albeit a very persistent one”

- Albert Einstein -

We do not have access to Reality directly. Our brains and our senses have evolved for survival. They have not evolved to see Reality for what it really is. We devise models that approximate Reality. We improve our models over time.

This paper is an attempt to prove Einstein right once again. As well, it serves as a Unifying Model of Reality. It brings together the Theory of Everything and it sheds Light to the problem of Consciousness. More importantly it points out to the state of the Universe and how we can turn things around.

The Universe is dying. It is heading towards a dead end.

Let's start with some definitions.

What is a Black Hole?

A Black Hole is something that sucks you in. You are drawn towards it. You cannot escape it. **Mind is a Black Hole.** You are drawn towards it. You cannot escape it. **The Universe is a Black Hole.** We are drawn towards it. We cannot escape it. Science says the universe is 95% dark. Let Science take another reading.

I introduce a new concept. The concept of a **WHITE HOLE.**

What is a White Hole? It is the opposite of a black hole. It is something that pushes you out. You cannot enter it. NOW is a White Hole. Every time you try to go to NOW it pushes you out to your Mind. NOW pushes the Universe away. NOW is a firehose. What is a firehose? It streams out fire. What is fire? Fire is light. So, the NOW hole is a Light hose. It shoots out Light. NOW is Consciousness itself. NOW is a white hole. It creates “me” and the “Universe”. It creates Duality. NOW is REALITY.

There is NOW and there is not NOW. NOW is the present moment absence of thought.

Not NOW is when you are not in NOW, when you are in thought.

NOW is Real, not NOW is not Real.

NOW is existence. The Mind and the Universe are non-existence. We pop in and out of existence. **The Mind and the Universe do not exist. The Universe is an illusion. The Mind is an illusion. Thoughts do not exist.**

“me” is what we know as ourselves in this world. Always in thought during the day and during dream sleep. “ME” is when I am in NOW, in absence of thought, and during Deep Sleep. There is “me” and there is “other”. There is “me” and there is the Universe”.

“Everything we call Real is made of things we cannot call Real”

- Niels Bohr -

The illusion of Time.

Time does not exist. Time is thought dependent. No thought, No Time.

Let's ride the thought. Let's start with being in NOW. You are in NOW and you go to your Mind. You follow your thought. After some time, you come back to NOW. The question is: What is the length of time that you were in thought? The answer is Zero. No time has elapsed. Thoughts travel at infinite speed. Thoughts travel at zero speed.

Distance = Velocity X Time. Distance = 0. Thought does not move anywhere. **Space does not exist.** It is an illusion of the Mind. Velocity = infinity. Velocity = 0. Time = 0.

All there is is NOW.

In the following figure we have the thought leaving the NOW hole and it returns to NOW.

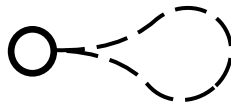

What do we do instead? We slice NOW into different portions and we call it Time. We start from NOW and we go into thought. We stay in thought and we come back to a different NOW. There is no different NOW. NOW is ONE. NOW is Consciousness. NOW is GOD.

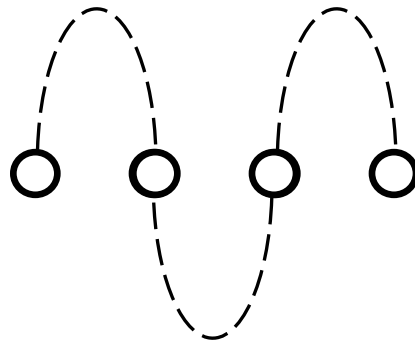

We have developed concepts and we use these concepts to measure Time. All concepts are thoughts. Thoughts do not exist. Only NOW is real. The Mind produces one thought at a time very fast. Each thought is launched and dies. No Time passes by.

**“It is not only possible but fairly probable, even, that psyche and matter are two different aspects of one and the same thing”
- Carl Jung -**

Duality is an illusion. If you are not in NOW, you are in thought. As soon as you are in thought you are in Duality.

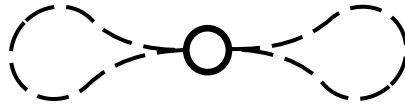

We view the world from a dualistic mindset, dualistic point of view.

Up/Down, Right/Wrong, **Mind/Matter**.

Meaning and Concepts are Thoughts, they are an illusion of the Mind.

The following figure shows the evolution of the Mind and of the Universe. Note that the circles in the center they all represent NOW. We are at 95% dark mark. Once we reach 100% black, we will be completely Mind. We will be completely detached from NOW, from Reality. Time is slowing down as we get closer to the event horizon. We have but a few decades to go to balance.

White = W, Black = B, Mind = M, Universe = U

EVOLUTION

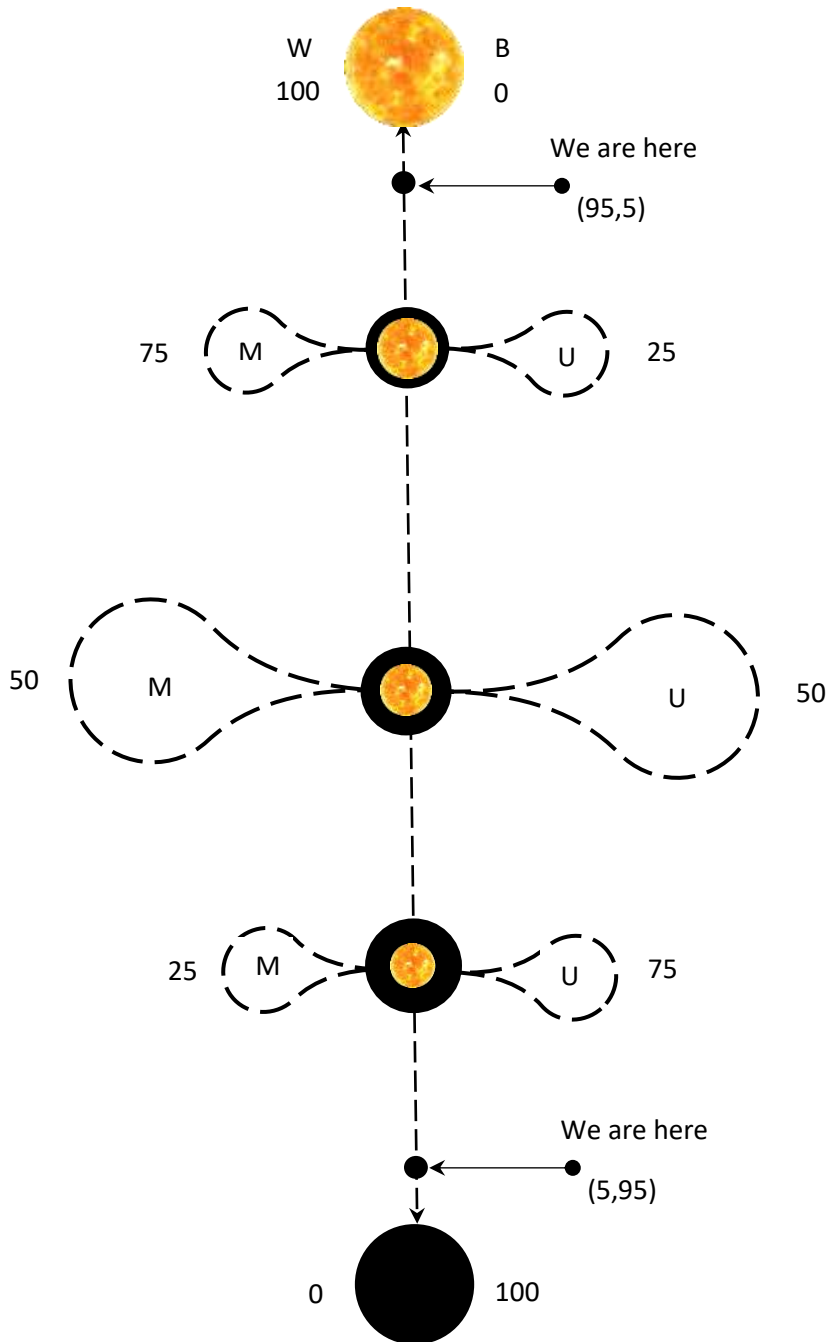

NOW is the Source of Light. The Mind does not exist; it is an illusion. Mind reflects the Universe. The Universe is a reflection, it is a mirror image of the Mind.

The Mind is a magic ball: What you wish is what you get.

The following diagram shows NOW in the center.

“me” and the “Universe” are mirror images of each other. **The Universe is expanding at the speed of thought.** Thought travels at infinite speed. The NOW hole in the center is 95% Dark. There is only 5% Light. Instead of the “Universe is expanding” one can say that the “Light is shrinking”.

“me” and the “Universe” are black holes and are being pushed away from the center. NOW pushes the Mind away and pushes the Universe away.

The black holes propel on thought. Our Minds are 95% in thought. Thoughts are rooted in FEAR and SUFFERING. They are Dark.

Big Bang is happening NOW. When you are in NOW all possibilities are available. White Hole, Black Hole and any Hole in between. The Universe is expanding, it is contracting and it is staying the same.

Knowledge is doubling every few years. The Universe is expanding at the same rate. If we connect our Minds to machines using BMI interfaces, we will be 100% in thought and we will lose touch of Reality. We will lose touch of NOW. The Universe collapses, Mind collapses, Duality collapses.

We need to go back to Awareness, back to Balance, 50/50, back to NOW.

White Hole & Black Hole Evolution

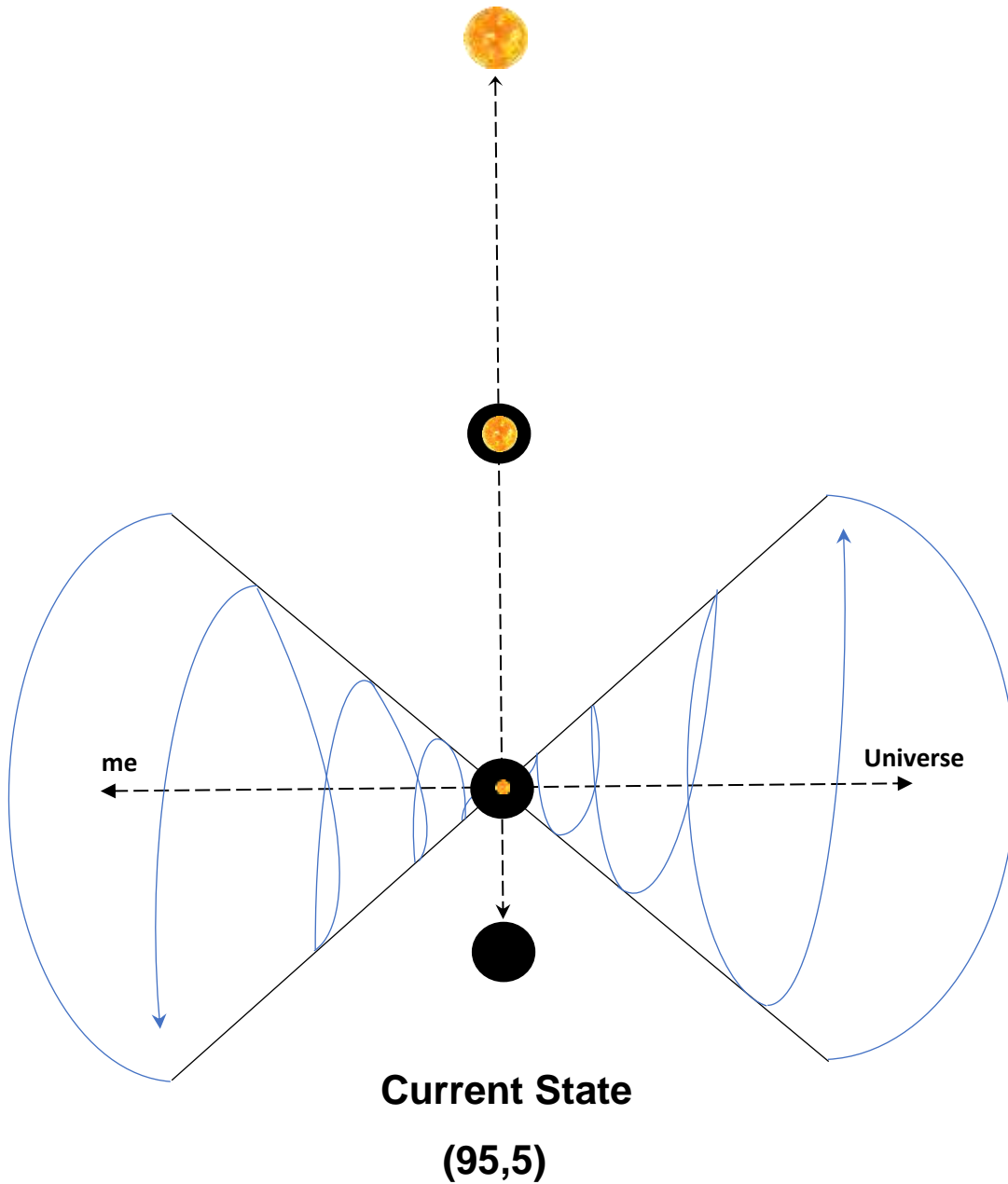

Balanced Mind ↔ Balanced World

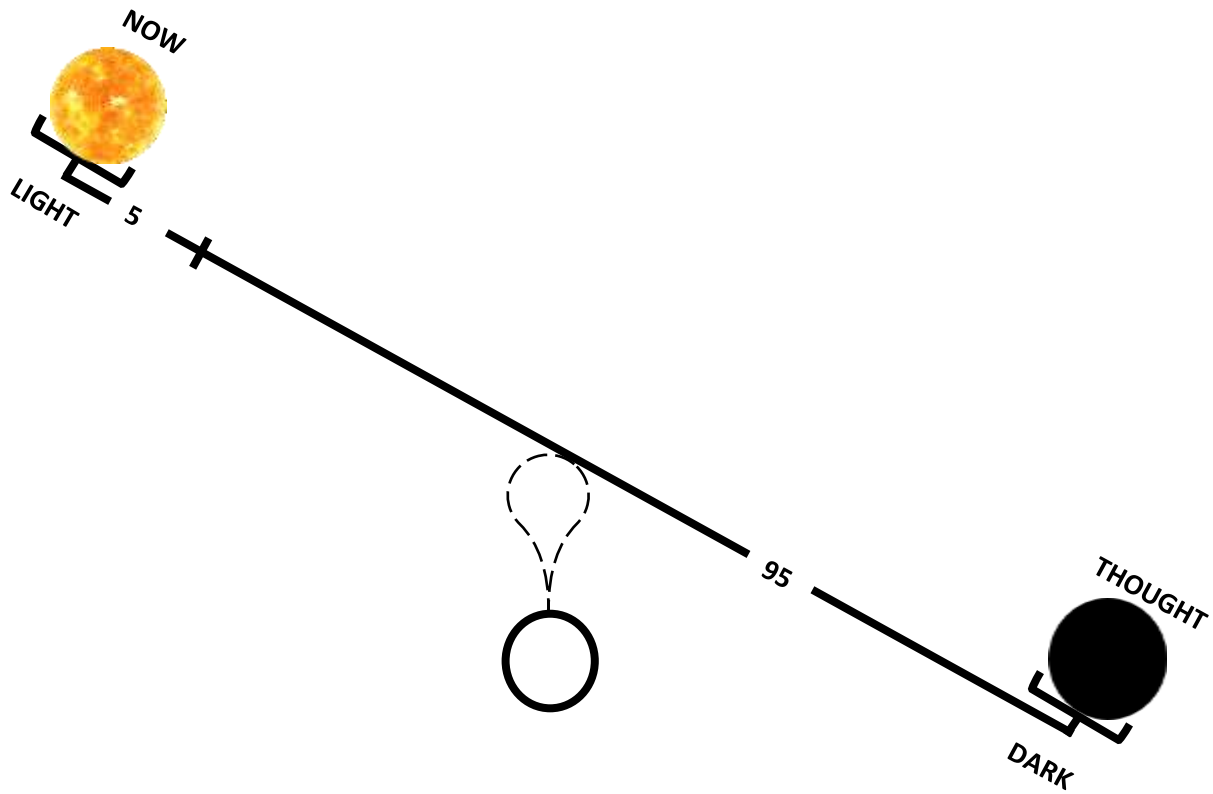

Act NOW!

TWUAITWUKTWUKITWUDTWUDITWUBTWUBITWUSTWUSITWUR

URSUKSUDSUBSUSSURS

URGUKGUDGUBGUSGURG

URTS

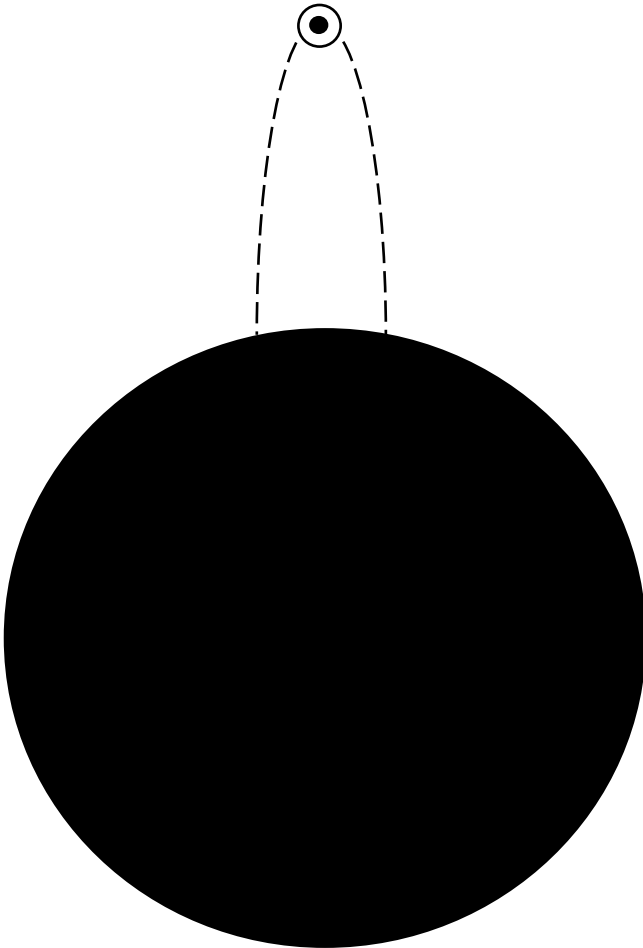

MAY THE SOURCE BE WITH
YOU

MESSAGE OF UNITY

WE ARE ONE

ONE CONSCIOUSNESS
ONE GOD

WE EXIST
WE ARE EXISTENCE
WE ARE AWARENESS
WE ARE NOW

WE HAVE ONE GOAL
BRING THE UNIVERSE HOME
BRING THE UNIVERSE TO BALANCE

WE NEED A NOW DIRECTION
WE NEED A NOW HABITUDE (HABIT + ATTITUDE)
WE NEED A NOW EDUCATION
WE NEED A NOW LEADERSHIP
WE NEED A NOW PARTY
WE NEED A NOW GOVERNMENT
WE NEED A NOW WORLD
WE NEED TO BE NOW

YOU ARE THE SOURCE OF LIGHT
YOU ARE THE SOURCE
URTS